



产品特性 Product features

- 应用于PCB塑料卡箍轴承无法被定位的场合。对配合孔的精度要求较低。螺栓固定无滑落风险
- 免维护，自润滑
- 螺丝固定安全可靠
- 适用于旋转、摇摆、直线运动
- 对安装孔精度无要求
- Suitable for the application where the CSB plastic clip bearing is hard to be located. The requirement of the fitting hole is not critical and the set screw could be secured without any risk of moving
- Maintenance free, self-lubricated
- Bolt fixture ensures safe and reliability
- Suitable for rotation, oscillation and sliding motions
- Low tolerance requirement for the mounting holes

结构设计 Structure design

CSB-FLB[®] 法兰轴承内外设计为无需外径压配合既符合轴承配合使用尺寸，故对配合座孔精度无特殊要求；采用螺丝固定轴承，使得轴承在座孔无法确保加工精度时更安全可靠地长久运行。

CSB-FLB[®] flange bearing is designed without housing fixture, no tolerance requirement for housing. With the bolt fixture structure, the bearings are reliably operated when housing is not possible to be designed.

材料设计 Material design

CSB-FLB[®] 法兰轴承采用坚固耐用的CSB-EPB3作为标准材料，轴承具较好的自润滑性能和长期的耐磨性能；可以完全干运行；同时CSB可提供低摩擦系数材料CSB-EPB13、耐高温达250℃的材料CSB-EPB5以及符合FDA食品安全等级材料CSB-EPB5A制成法兰轴承。

CSB-FLB[®] is made from CSB-EPB3 material which is a solid material with good self-lubricating performance and anti-wear feature suitable for dry operation conditions. At the same time, CSB also provides flange bearings with different materials such as low friction CSB-EPB13, high temperature material CSB-EPB5 and FDA approved CSB-M70 etc.

安装设计 Assembly design

法兰轴承设计采用螺丝固定使得轴承在长期运动中更为安全可靠。虽然我们设计对轴承配合座孔精度无要求，但如需要获得最佳的使用性能CSB推荐配合座孔为H7公差。

The bolt fixture designation of the flanged bearing ensures a long term reliable operation of the bearings. Although there is no matching housing tolerance requirement, a better operation condition could be achieved if a recommended housing tolerance of H7 is available.

标准规格 Standard specifications

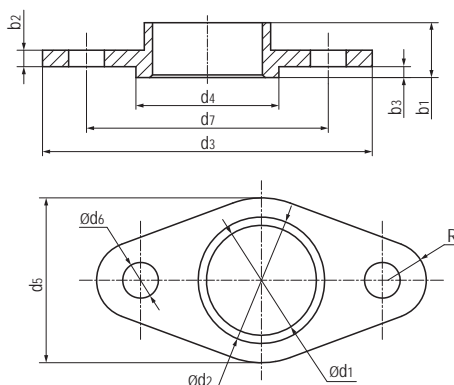

产品编码 Part No.:

FLB3-10

内径 Inner diameter

材料 Material: EPB3
EPB5
EPB13

座孔 Housing: H7 轴 Shaft: h9

产品编码 Part No.	d ₁ [mm]	公差 Tolerance [mm]	d ₂ [mm]	d ₃ [mm]	d ₄ [mm]	d ₅ [mm]	d ₆ [mm]	d ₇ ± 0.2 [mm]	b ₁ [mm]	b ₂ [mm]	b ₃ [mm]	R [mm]
FLB3-10	10	+0.025/+0.083	12	30	14	15	4.5	22	6	2	1	4
FLB3-12	12	+0.025/+0.083	14	36	16	18	4.5	26	6	2	1	4.5
FLB3-14	14	+0.025/+0.083	16	42	18	21	5.5	30	6	2	1	5
FLB3-16	16	+0.025/+0.083	18	48	20	24	5.5	34	6	2	1	5.5
FLB3-18	18	+0.025/+0.083	20	54	22	27	6.5	39	6	2	1	7
FLB3-20	20	+0.040/+0.124	23	60	26	30	6.5	44	10	3	2	7
FLB3-25	25	+0.040/+0.124	28	75	30	35	6.5	55	10	3	2	8.5
FLB3-30	30	+0.040/+0.124	34	90	36	40	8.5	66	10	3	2	10
FLB13-10	10	+0.025/+0.083	12	30	14	15	4.5	22	6	2	1	4
FLB13-12	12	+0.025/+0.083	14	36	16	18	4.5	26	6	2	1	4.5
FLB13-14	14	+0.025/+0.083	16	42	18	21	5.5	30	6	2	1	5
FLB13-16	16	+0.025/+0.083	18	48	20	24	5.5	34	6	2	1	5.5
FLB13-18	18	+0.025/+0.083	20	54	22	27	6.5	39	6	2	1	7
FLB13-20	20	+0.040/+0.124	23	60	26	30	6.5	44	10	3	2	7
FLB13-25	25	+0.040/+0.124	28	75	30	35	6.5	55	10	3	2	8.5
FLB13-30	30	+0.040/+0.124	34	90	36	40	8.5	66	10	3	2	10

*d₁公差为压入标准H7座孔（符合ISO3547-1）后公差 *Tolerance d₁ after fitting into housing H7 (ISO3547-1)

FLB法兰轴承安装方式 Flange bearings installation method

